

USER'S GUIDE

Auto-barrier systems

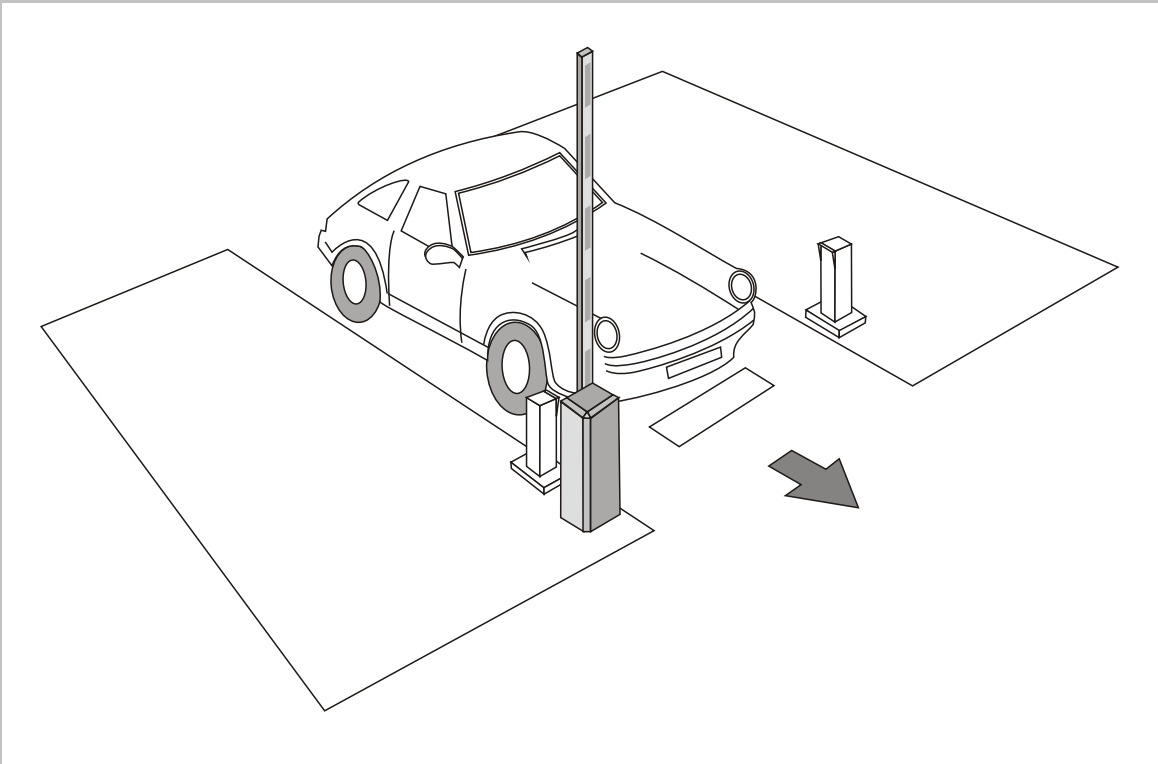

IMPORTANT SAFETY INSTRUCTIONS WARNING

IT IS IMPORTANT FOR THE SATETY OF PERSONS TO FOLLOW ALL INSTRUCTIONS.

1. Before starting installation and operation or maintenance work, make sure to cut off power supply.
2. The cabinet must be earthed. And an earth leakage breaker is necessary on the power supply.
3. As for electric cable type and section, we suggest the use of appropriate cabel according to the local regulations.
4. Do not change the original inside wiring.
5. If power failure, please switch off the power supply first, then open the door and rotate the handle under the motor manually to open the boom all.
6. Keep the automatic control (push-button, remote control, etc) out of the reach of children. The control systems must be installed at a minimum height of 1.5m from the ground surface.
7. Use transmitters only if you can see the gate.
8. It is forbidden to open the door or the cover of the cabinet when the machine is working.
9. This instruction booklet is exclusively dedicated to specialized staff who are aware of the construction criteria and of the accident prevention protection devices for motorized gates and doors (according to the current regulations and laws).

NOTE: If the barrier is equiped with control unit MC1 from MOTORLINE ,the installer should read control unit manual to know how to set additional functions such as slow start and slow stop.

A. Technical specifications

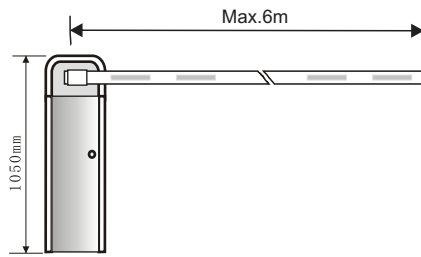

Power supply: 220V/50Hz 90W
R.P.M: 2800r/min
Time for up/down: 3~6S
Max boom length: According to model (Max.6m)

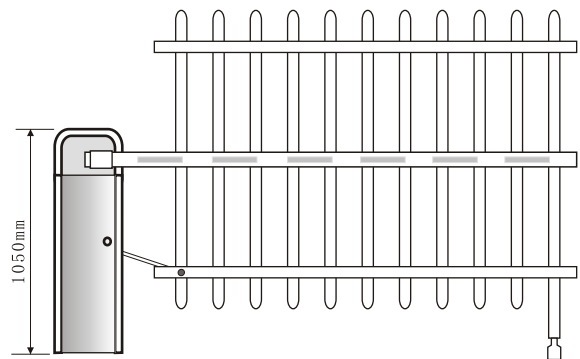
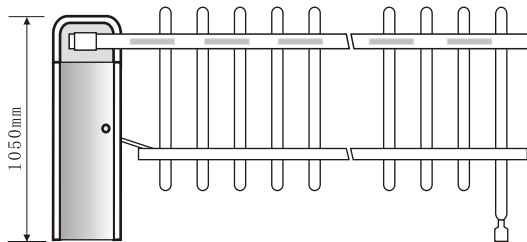
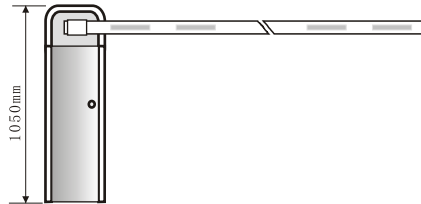
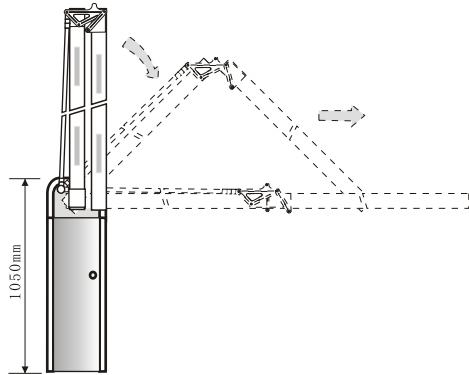

B. Installing and adjusting

1. Install the machine on the ground

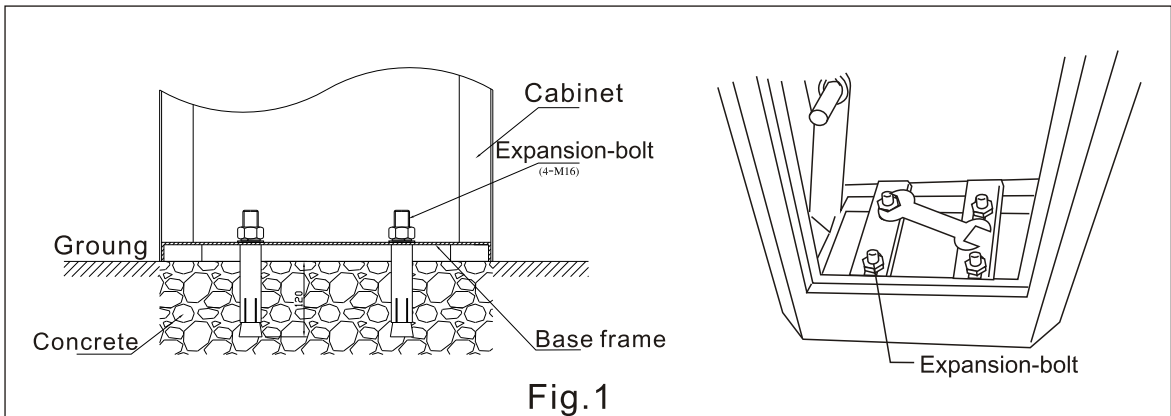

2. Install boom(Fig.2)

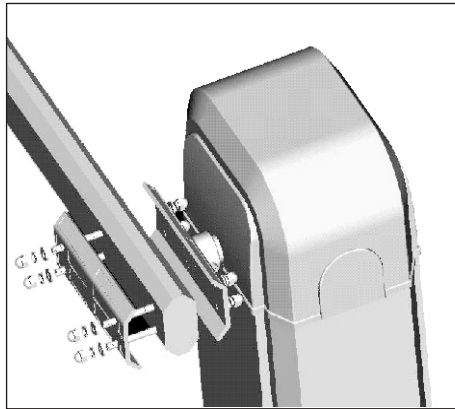
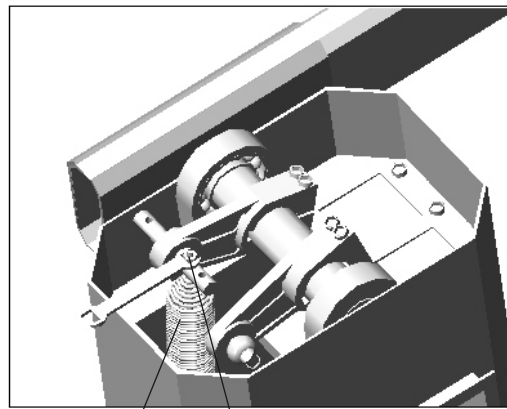

Fig.2



Spring Adjust nut Fig.3

3. Adjust the spring's balance(Fig.3)

IMPORTANT:

The barrier is supplied with springs already balanced for the max. boom length (6m)

If the boom is smaller, you must adjust spring force in order to make the barrier stop along its course when needed.

Procedure:

1°- Turning knob clockwise, disengage barrier (Fig.5)

2°- Move manually boom on opening direction 50cm in 50cm ,where without assistance it must be fixed. In case of barrier movement you should give or remove spring force (Fig.3)

3°- Repeat the previous steps as many times as needed until boom stay completely balanced

4°- With spring completely balanced, close barrier manually

5°- Engage barrier ,turning knob anti-clockwise.

boom LENGTH	NUMBER OF SPRING	SPRING LENGTH
3m	1	440mm
4m--4.5m	2	440mm
5m--6m	3	440mm

4. Adjust the limit position

Barrier can be supplied with magnetic limits (B) , mechanicals limits (A) or both.

You must adjust first the mecanical ones (A) in order to make the desired route, adjusting then magentic ones(B) for safety reasons.Since they are connected in serie with the mecanicals ,set them to act soon after these.

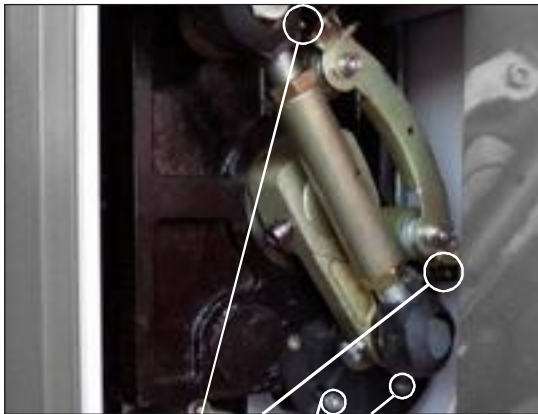

Mechanical (A) Magnetics (B)

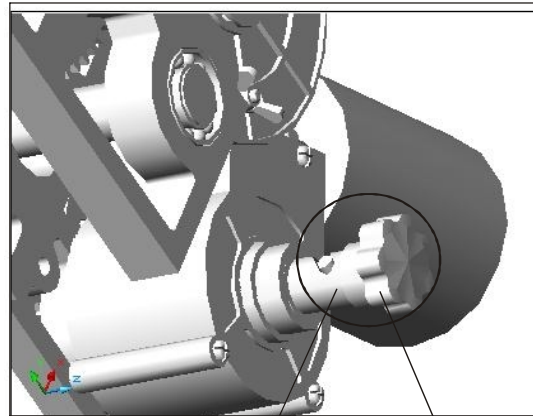

Lock Unlock

Fig.4

Fig.5

C. Electrical safety devices(Fig.5)

The BARRIERS limit switches, motor and control unit are already connected.

Only the photo cells, the loop detector and the supply voltage have to be connected

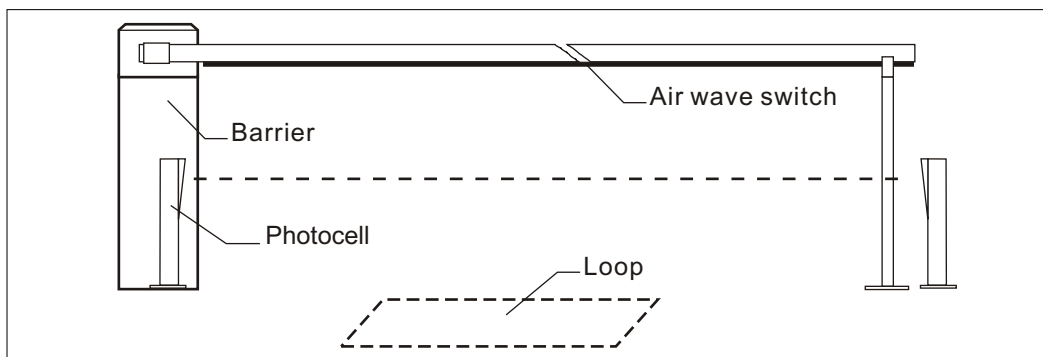

Fig:5